



Cast Iron Boilers

A Series (105-300kW)

## Mikrotherm A Series Cast Iron Boilers

The Mikrotherm A Series of cast iron sectional boilers offer all the advantages of cast iron durability and longevity coupled with high efficiency and ease of operation. The range offers outputs of 100 -300 kW for oil or gas fired operation.



The Mikrotherm G series incorporates a unique three pass design feature allowing the boiler to be operated at low return temperatures. The hinged front door allows for easy access for maintenance and cleaning tools are supplied as standard. The high levels of insulation ensure minimum heat loss and maximum noise reduction.

The standard control package includes illuminated on/off switch, high and low control thermostats, hours run meters and high limit thermostat with test switch, Higher levels of control specification are available as an optional extra.

The compact design and unique design features make the Mikrotherm A Series boiler a perfect choice for both new and retrofit applications.

## Standard features

The Mikrotherm A Series includes six boilers (with 4 to 9 sections) giving output from 80 to 300kW. Oil, gas or dual fuel.

- Compliance with standards:  
The boilers are CE marked in accordance with: Gas Appliances Directive (90/396/EEC), Boiler Efficiency Directive (92/42/EEC), Electromagnetic Compatibility Directive (89/336/EEC) and conform to EN 303/1, 303/2 and 303/3.
- Operation at low return water temperatures  
All Mikrotherm A Series boilers utilises recirculation in the rear two sections of the boiler thereby instantly raising the incoming water temperature and allowing the boilers to be operated at continuous return temperatures of 30 and 40°C for oil and gas respectively without the formation of condensation. This feature also protects the boiler from thermal stresses affording long and dependable life.
- Simplified installation  
The ability of the boiler to operate condensate free at continuous low return temperatures allows installations to be made without the need for 'back-end temperature protection'. A shunt pump therefore is not required.

Minimal flow rate must be observed – see technical data.

- Heat exchanger construction  
The heat exchangers are constructed from cast iron sections and interconnected using bi-conical nipples, all held together with tie rods. Section to section gas tight sealing is afforded using woven ceramic rope bonded into place. The combustion chamber doors are heavily insulated with factory fitted ridged ceramic linings.
- Warranty against material or manufacturing defect:  
Heat exchanger – 10 years  
Burner – not less then 12 months but certain burners may have longer warranties  
All other components – 12 months

## Integral backend protection

A special connector positioned in the return connection port, induces recirculation in the rear two sections of the boiler which instantaneously raises the return water temperature, thereby allowing continuous operation at low return water temperatures (even when firing on oil) without condensation and thermal shocks. See technical data for minimum continuous return temperatures.

This feature affords simplified installations without backend temperature protection necessity and has the possibility for variable temperature installation to be made without mixing valves.

Note there is a requirement to observe minimum flow rate – see technical data.

## Boiler door

All boilers have double hinged full boiler sized front door, allowing unrestricted and easy access for cleaning and inspection of the combustion chamber and flueways.



## Minimum water flow rate

A minimum water flow rate must be provided at all times either via the main system pump/s or via shunt pumps. The boiler and burner must be interlocked to the pumps and the burner must be prevented from firing in the event of water flow failure.

In case of multiple boilers with individual shunt pumps, it is important to install non-return valves upstream of the return connection to avoid parastatic flow between boilers. See diagram below.

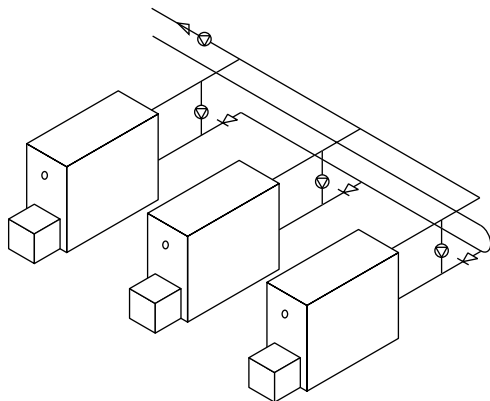

## Installation requirements

The Mikrotherm A Series boilers must be installed in accordance with (as appropriate) the requirements of the Building Regulations, Health and Safety Executive Regulation PM5, IEE Regulations, Gas Safety (Installations and Use) Regulation, National Water Byelaws, Clean Air Act Memorandum on Chimney Heights and any insurance company requirements.

### Codes of practice

- BS6880 (Parts 1, 2 and 3. 1988) Code of Practice for low temperature hot water heating systems for output greater than 45kW.
- BS5410 (Part 2. 1978) Code of Practice for oil firing installation of output greater than 44kW for space heating, hot water supply and steam supply purposes,.
- BS6644 (1991) Specification for installation of gas fired hot water boilers of rated inouts between 60kW and 2MW.
- IGE/UP/2 Gas installation pipework, boosters and compressors on industrial and commercial premises.
- CIBSE Reference sections B7, B11 and B13
- LPG When boiler are fired with LPG, it is recommended that gas leakage detection equipment is installed at low level near the boiler/s.

## System water quality

Mikrotherm A Series boilers must always be installed on closed systems, whether they are open vented or sealed and pressurised type. All systems should be thoroughly cleaned prior to installation of the boiler and the system water must be treated to prevent the deposition of scale or sludge in the waterways.

The system water be of sufficient quality to maintain the following requirements:

- pH between 7.5 and 8.5
- Maximum hardness of between 8 and 12 grams of calcium carbonate per 100 litres of water.

## Filling the system

The system to which the boilers are connected may be open vented or sealed and pressurised (recommended). If the system is to be of the sealed type, then the initial filling of a sealed system and subsequent refilling, must be by a method that has been approved by the Water Regulation Advisory Scheme (WRAS) for the type of heating system i.e. Fluid Category 4 (commercial). We recommend the using a Mikrofill EFD, our patented sealed system filling device. See typical installation diagram.

## Typical installation

For sealed systems Mikrofill recommends the use of the Mikrofill EFD sealed system filling device. The EFD is the most compact and advanced filling and pressurisation unit available. It is an approved

category 4 backflow preventor, can fill and pressurise your system from empty and provides microprocessor controlled pressure and leakage management.

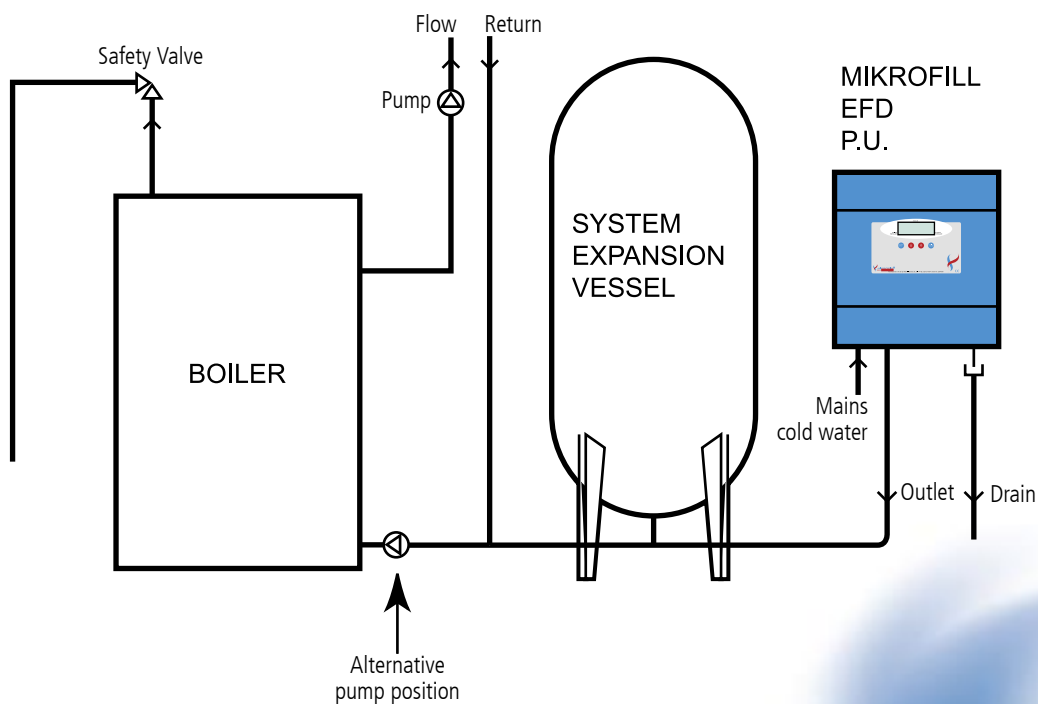

## Technical data

Output						
Model	A4	A5	A6	A7	A8	A9
Output (kW)	105	144	184	223	262	300
Nett input (kW)	115	158	202	245	288	329
No. Sections	4	5	6	7	8	9

Dimensions						
Model	A4	A5	A6	A7	A8	A9
Overcase length 'L' (mm)	744	878	1012	1146	1280	1414
Overcase width (mm)	780					
Overall height (mm)	1020					
Weight (kg)	430	510	590	670	750	830

## Dimensions diagram

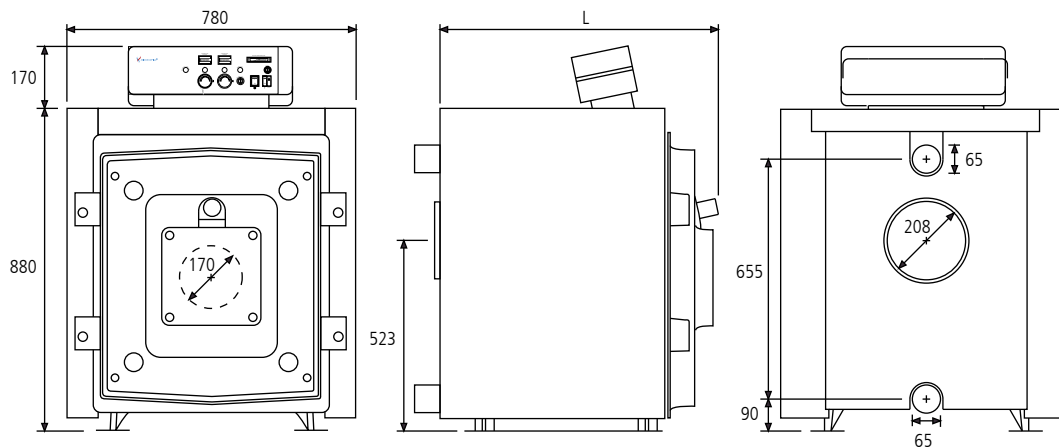

## Boiler base

Recommended dimensions of plinth (mm)						
Model	A4	A5	A6	A7	A8	A9
Width	830					
Length	775	905	1035	1165	1295	1425
Height	150					

## Clearances

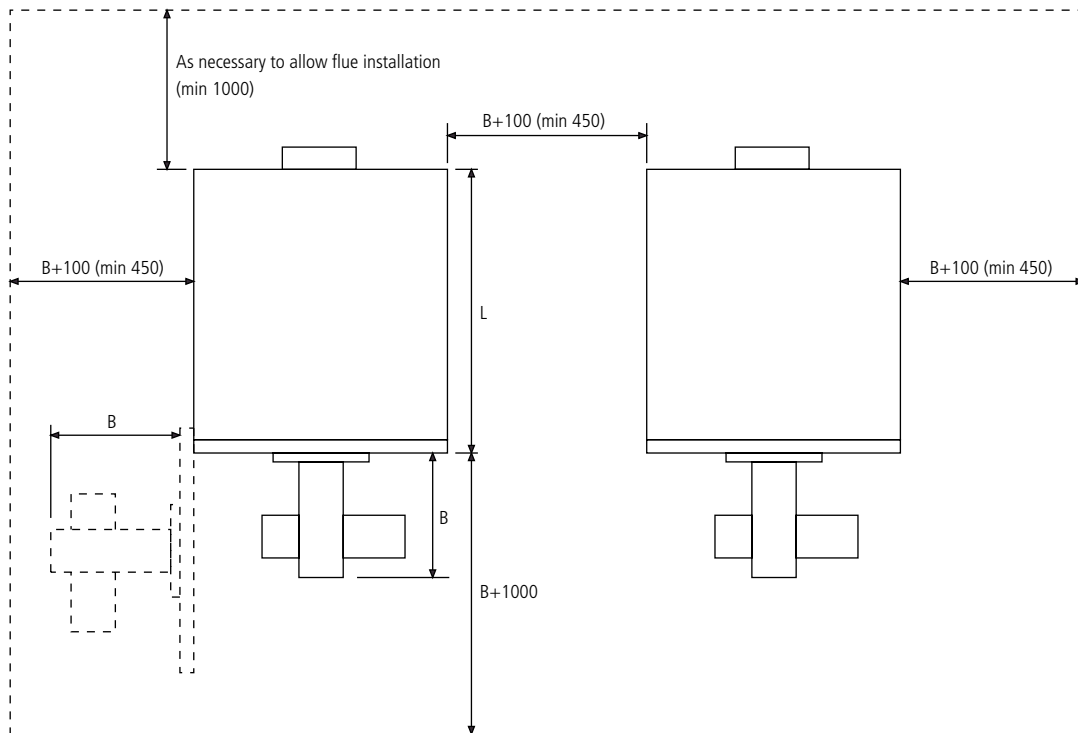

		Burner depth 'B' (mm)					
Model		A4	A5	A6	A7	A8	A9
Riello	Oil	265	299	468			
	Gas	389		580			
NuWay	Oil	405	488		390	580	
	Gas	392	435		580		
EOGB	Oil	410			535		605
	Gas	585				770	



## Technical data

Waterside Data						
Model	A4	A5	A6	A7	A8	A9
Minimum flow rate (litres/second)	0.41	0.58	0.75	0.88	1.05	1.19
Minimum return temp for gas (°C)	25					
Minimum return temp for oil (°C)	35					
Maximum working pressure (bar)	4					
$\Delta t = 10^{\circ}\text{C}$						
Design flow (litres/second)	2.5	3.42	4.38	5.3	6.23	7.14
Resistance (kpa)	8.1	16	15.5	20.6	29.5	39
$\Delta t = 15^{\circ}\text{C}$						
Design flow (litres/second)	1.66	2.28	2.92	3.53	4.15	4.76
Resistance (kpa)	3.7	7.2	6.8	9.2	13.2	17.4
$\Delta t = 20^{\circ}\text{C}$						
Design flow (litres/second)	1.25	1.71	2.19	2.65	3.11	3.57
Resistance (kpa)	2.2	4.1	3.9	5.2	7.5	9.8

Flue gas data						
Model	A4	A5	A6	A7	A8	A9
Flue spigot outside diameter (mm)	208					
Flue spigot inside diameter (mm)	200					
Nominal flue gas temp (°C)	185					
Wet gas volume (kg/hour)	185.1	253.9	324.4	393.1	461.9	528.9
Wet gas volume (kg/hour)	176.3	241.9	309	374.5	439.9	503.8
Standing losses (Watts)	133.4	168	188	215	243.6	270.3

Fuel consumption						
Model	A4	A5	A6	A7	A8	A9
Output (kW)	105	144	184	223	262	300
Nett input (kW)	115	158	202	245	288	329
Max gas rate (m <sup>3</sup> /hour)	11.98	16.5	21.04	25.57	29.97	34.36
Max LPG rate (m <sup>3</sup> /hour)	8.83	12.16	15.5	18.83	22.07	25.31
Max 35sec Oil rate (kg/hour)	9.7	13.35	17	20.7	24.24	27.8

## Electrical schematic

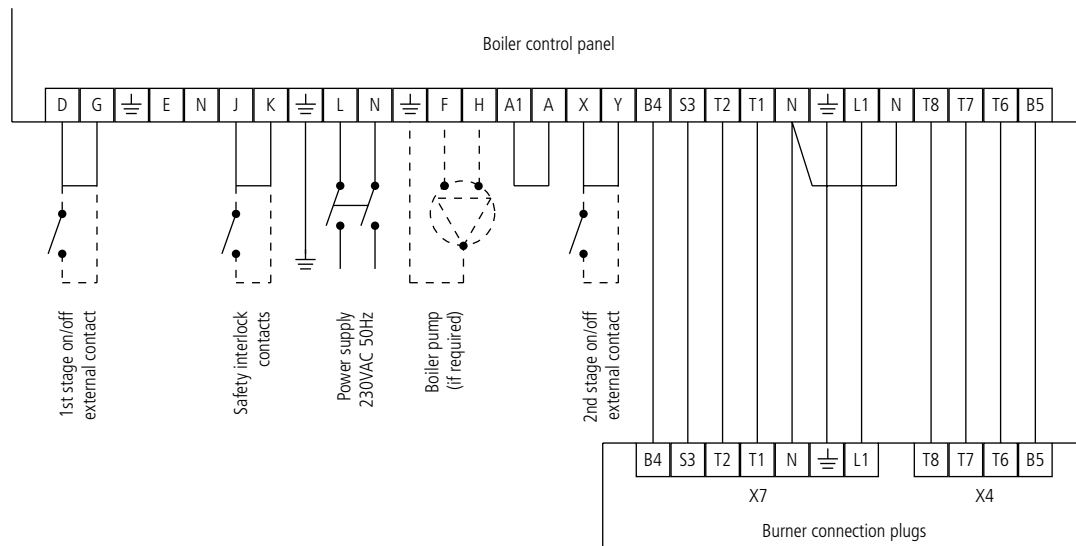

### Notes

- Maximum current that can be switched per output is 2A. Provide a contactor for any output above that value.
- Remove link D-G and install a volt free contact to achieve remote external on/off control
- Remove links X-Y and install volt free contact to achieve remote high/low control (high/low burners only)

## Boiler control panel

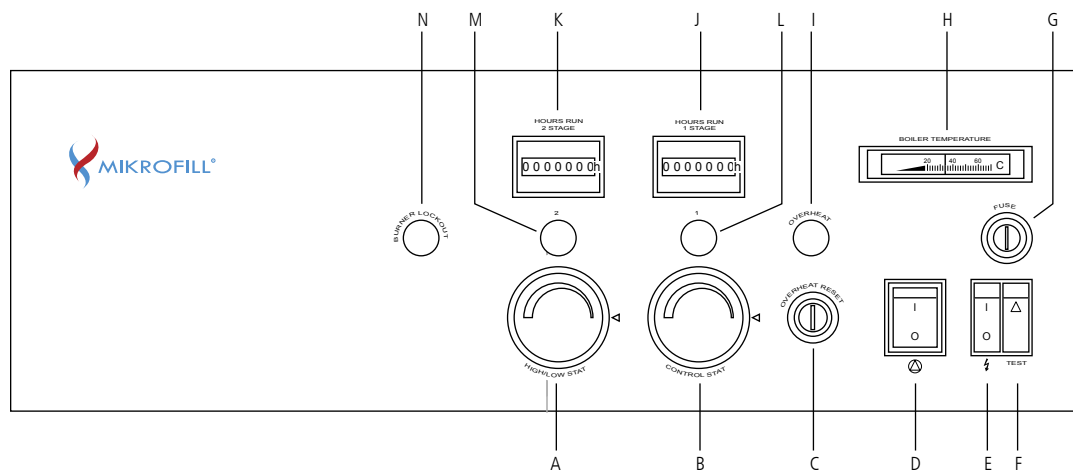

### Key to components

A	2nd stage control thermostat	H	Water temperature thermometer
B	1st stage control thermostat	I	Overheat trip lamp
C	High limit thermostat	J	1st stage hours run
D	Pump control switch	K	2nd stage hours run
E	Burner on/off switch	L	1st stage operating lamp
F	High limit thermostat test switch	M	2nd stage operating lamp
G	Fuse holder	N	Burner lockout indicator lamp

## Optional climate control panel

As an alternative, where installation utilizes a single Mikrotherm A Series boiler, the boiler may be equipped with an enhanced fully automatic control panel (at additional cost) which included a comprehensive controller (Siemens RVA53.280). This controller can provide control over two heating zones with weather compensation, plus control over an indirect water storage cylinder such as the Mikrofill Rapide.

The features of the 'P3' control panel are as follows:

- 2 separately controlled heating circuits without mixing valves
- Quick setback and boost facility
- Automatic summer/winter changeover
- Remote operation via digital room unit
- Self adaptive in line with thermal dynamics of the building
- Automatic adjustment of heating curve to type of building construction and the heat demand (provided a room unit is connected)
- Adjustable flow temperature boost with mixing heating circuit
- Protective boiler start-up
- Protection against boiler over temperature (pump overrun)
- Adjustable minimum and maximum limitation of boiler temperature (boiler flow temperature)



West Court  
Buntsford Park Rd  
Bromsgrove  
B60 3DX

**T**  
+44 (0) 1527 574574  
**F**  
+44 (0) 1527 575565

**W**  
mikrofill.com  
**E**  
info@mikrofill.com

**Part L**  
Compliant  
**Part J**  
Compliant  
(Scotland)



Certificate No. 8706

Mikrofill is a registered trademark of Mikrofill Systems Ltd